

Product Name
Electric Drill
Product Code
MPED300VD
Articls Code
111-0205
Version
21-0005
Date
2021-08-11

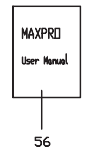
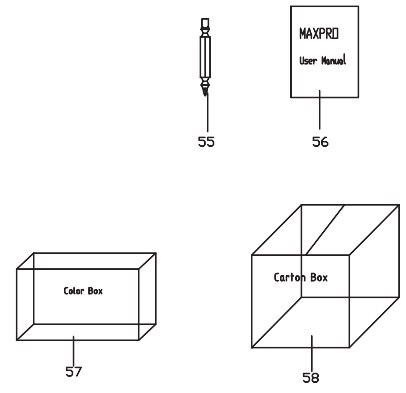

MPED300VD SPARE PART LIST

PART NO.	ARTICLE CODE	DESCRIPTION	SPECIFICATION	WEARING PART	QTY REQUIRED
1	111-0205-001	Screw	M5x20-L	×	1
2	111-0205-002	Chuck	0.8-10mm	×	1
3	111-0205-003	Screw	ST2.9X18	×	2
4	111-0205-004	Setting plate	PA6+GF30	×	1
5	111-0205-005	Shrapnel block	PA6+GF30	×	1
6	111-0205-006	Shell splinter	65Mn	×	1
7	111-0205-007	Torque Adjusting Disc	PA6+GF30	×	1
8	111-0205-008	Inner ring of torque Adjusting Disc	PA6+GF30	×	1
9	111-0205-009	Big Spring	65Mn	×	1
10	111-0205-010	Big Washer	∅40*∅30	×	1
11	111-0205-011	Small Washer	∅12	×	1
12	111-0205-012	Steel Ball Washer	∅12.5*∅17.5*0.5	×	3
13	111-0205-013	Steel Ball	S ∅3	×	15
14	111-0205-014	Steel Ball	S ∅5	×	12
15	111-0205-015	Shaft Sleeve	Ferrous powder metallurgy	×	1
16	111-0205-016	Gear Box	PA66+GF30	×	1
17	111-0205-017	Output Shaft	#45	×	1
18	111-0205-018	Annular gear	Ferrous powder metallurgy	×	1
19	111-0205-019	Three stage planetary gear	Ferrous powder metallurgy	×	3
20	111-0205-020	Gear Gasket		×	1
21	111-0205-021	Rear gear box	PA66+GF30	×	1
22	111-0205-022	Shift wire	65Mn	×	1
23	111-0205-023	Screw	ST2.9*12	×	1
24	111-0205-024	Three wheel center	Ferrous powder metallurgy	×	1
25	111-0205-025	Gear ring	Ferrous powder metallurgy	×	1
26	111-0205-026	Two stage planetary gear	Ferrous powder metallurgy	√	3
27	111-0205-027	Two wheel center	Ferrous powder metallurgy	√	1
28	111-0205-028	Primary inner ring gear	Ferrous powder metallurgy	√	1
29	111-0205-029	Primary planetary gear	Ferrous powder metallurgy	√	3
30	111-0205-030	Gear gasket	Thickness 0.8	×	1
31	111-0205-031	The motor fixing frame	PA66+GF30	×	1
32	111-0205-032	Shift button	PA6+GF30	×	1
33	111-0205-033	Push button shrapnel	Steel	×	2
34	111-0205-034	Left Housing	PA6+GF30/TPE	×	1
35	111-0205-035	Brand Lable		×	1
36	111-0205-036	Paper gasket		×	1
37	111-0205-037	Bearing	6900ZZ	×	1
38	111-0205-038	Rotor		√	1
39	111-0205-039	Carbon brush holder	PA6+GF30	×	1
40	111-0205-040	Carbon brush sleeve		×	2
41	111-0205-041	Carbon brush		√	2
42	111-0205-042	Carbon brush cover		×	2
43	111-0205-043	Bearing	607ZZ	×	1
44	111-0205-044	Stator		√	1
45	111-0205-045	Positive and reverse push button	PA6+GF30	×	1
46	111-0205-046	Switch		√	1
47	111-0205-047	LED Control Plate		×	1
48	111-0205-048	Cable Clamp Plate	Q195	×	1
49	111-0205-049	Screw	ST4.2*10	×	2
50	111-0205-050	Cord Sleeve	PVC	×	1
51	111-0205-051	Power cord		×	1
52	111-0205-052	Right housing	PA6+GF30	×	1
53	111-0205-053	Screw	ST3.5*14	×	11

MPED300VD SPARE PART LIST

PART NO.	ARTICLE CODE	DESCRIPTION	SPECIFICATION	WEARING PART	QTY REQUIRED
54	111-0205-054	Rating lable		×	1
55	111-0205-055	Double-end Drill Bit		√	1
56	111-0205-056	Manual		×	1
57	111-0205-057	Color box		×	1
58	111-0205-058	Cartion box		×	1

Assembly

PART NO.	ARTICLE CODE	DESCRIPTION	SPECIFICATION	WEARING PART	QTY REQUIRED
59	111-0205-059	Gear box assembly		√	1
3	111-0205-003	Screw	ST2.9X18	/	/
4	111-0205-004	Setting plate	PA6+GF30	/	/
5	111-0205-005	Shrapnel block	PA6+GF30	/	/
6	111-0205-006	Shell splinter	65Mn	/	/
7	111-0205-007	Torque Adjusting Disc	PA6+GF30	/	/
8	111-0205-008	Inner ring of torque Adjusting Disc	PA6+GF30	/	/
9	111-0205-009	Big Spring	65Mn	/	/
10	111-0205-010	Big Washer	∅40*∅30	/	/
11	111-0205-011	Small Washer	∅12	/	/
12	111-0205-012	Steel Ball Washer	∅12.5*∅17.5*0.5	/	/
13	111-0205-013	Steel Ball	S ∅3	/	/
14	111-0205-014	Steel Ball	S ∅5	/	/
15	111-0205-015	Shaft Sleeve	Ferrous powder metallurgy	/	/
16	111-0205-016	Gear Box	PA66+GF30	/	/
17	111-0205-017	Output Shaft	#45	/	/
18	111-0205-018	Annular gear	Ferrous powder metallurgy	/	/
19	111-0205-019	Three stage planetary gear	Ferrous powder metallurgy	/	/
20	111-0205-020	Gear Gasket		/	/
21	111-0205-021	Rear gear box	PA66+GF30	/	/
22	111-0205-022	Shift wire	65Mn	/	/
23	111-0205-023	Screw	ST2.9*12	/	/
24	111-0205-024	Three wheel center	Ferrous powder metallurgy	/	/
25	111-0205-025	Gear ring	Ferrous powder metallurgy	/	/
26	111-0205-026	Two stage planetary gear	Ferrous powder metallurgy	/	/
27	111-0205-027	Two wheel center	Ferrous powder metallurgy	/	/
28	111-0205-028	Primary inner ring gear	Ferrous powder metallurgy	/	/
29	111-0205-029	Primary planetary gear	Ferrous powder metallurgy	/	/
30	111-0205-030	Gear gasket	Thickness 0.8	/	/
31	111-0205-031	The motor fixing frame	PA66+GF30	/	/

60	111-0205-060	Rotor assembly		√	1
37	111-0205-037	Bearing	6900ZZ	/	/
38	111-0205-038	Rotor		/	/
43	111-0205-043	Bearing	607ZZ	/	/

61	PM-01	Power Cord Tie	2*18.5cm	/	1
62	PM-04	Sealed Bag	16*24	/	1
63	PM-02	MAXPRO Parcel Tape	5cmwide, 80m/roll, printing	/	1
64	PM-03	Joint Sticker	∅2.2cm	/	1
65	PM-06	PE Bag	30*40	/	1